

PST POST TOP AREA LIGHT CCT3

PROJECT: _____

SCHEDULE: _____ DATE: _____

PREPARE BY: _____

NOTES: _____

DESCRIPTION

naturaLED® has designed a sleek, contemporary post top fixture with three vertical arm that creates a clean look. Easy installation to retrofit on standard 2-3/8" tenons, 3" Pole. Saving time and money by upgrading to LED. Our DLC premium open round post top light fixture replaces up to 400 watt metal halide fixtures and produces up to 13,000 lumens.

BENEFITS

Sleek, contemporary design eliminates light trespass to avoid light pollution in the night sky.



Dusk to Dawn Photocell Sensor
Adjustable Wattage and CCT

Rated Life 50,000 Hours
Warranty 5 Years

APPLICATIONS

Corporate Campus, Education, Healthcare, Parking Structure, Parks, Hospitality, Walkways, Commercial office buildings, Landscape lighting may come into use

FEATURES

- DLC Premium
- IP65 Rated
- ETL Listed
- Selectable Wattages (3 Wattages)
- Selectable Color Temperature (3000K, 4000K, 5000K)
- Voltage: 120-277V
- Power Factor >0.9
- Surge Protection: 4KV
- Beam Angle: 110°
- Dimmable: 0-10V
- CRI: >80
- Operating Temperature: - 40°F - 122°F
- Built-in photocell sensor (turn on and off)
- Mounting: Fits 2-3/8" Tenon / Fits 3" Pole
- Recommended Mounting Height: 8-15ft
- Glass Lens
- Color: Black
- 5 Year Warranty
- Optional for Purchase: Surge Protector

ACCESSORIES



PHOTO SENSOR & SELECTABLE

Selectable Wattage & CCT Dusk to Dawn Photocell Sensor On/Off Switch

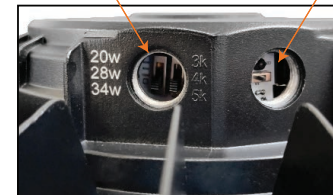

SAMPLE NUMBER **FX15PST100SW/8CCT3/BK**

FAMILY	DIAMETER	SERIES	WATTAGE	CRI/COLOR TEMP	COLOR
FX Fixture	15 15-inch	PST Post Top	100SW Selectable Wattage 60W/80W/100W	8CCT3 CRI 80 3000/4000/5000K	BK Black



POST TOP AREA LIGHT CCT3

PARKING & AREA LUMINAIRES

ORDERING

*P= Premium DLC / *S = Standard DLC

Watts (W)	Ordering Code	Description	CCT (K)	Lumens (Lm)	Equiv. Wattage (W)	Dim (V)	IP65 Rated	DLC (S/P)
20	9571	FX15PST34SW/8CCT3/BK	3CCT (3/4/5K)	3,004	175	0-10V	●	P
28				4,200				
34				5,262				
60	9572	FX15PST100SW/8CCT3/BK	3CCT (3/4/5K)	8,104	250	0-10V	●	P
80				10,400				
100				13,361				

ACCESSORIES (Ordered Separately)

Surge Protector



P10389 SPD-L-10KV-277
(10KV Surge protector/ 120-277V)



P10390 SPD-L-20KV-277
(20KV Surge protector/ 120-277V)

DIMENSIONS

34W / 100W
8.8-lbs / 8.8 -lbs

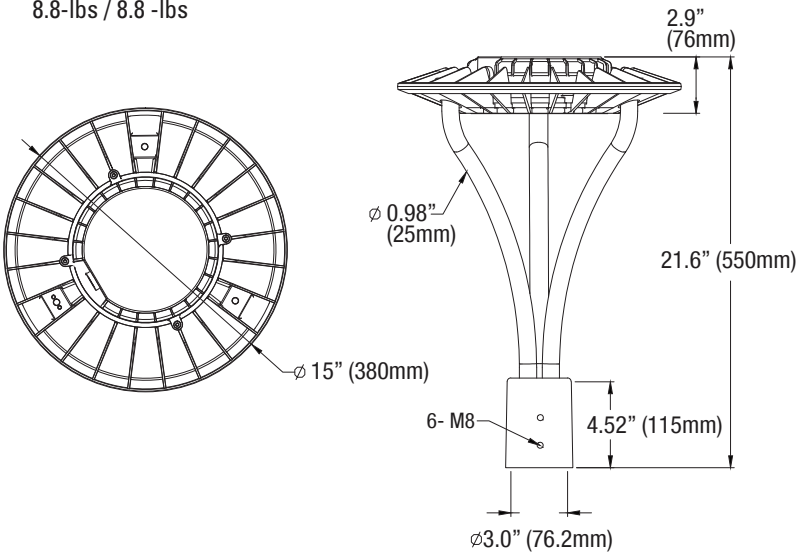

PHOTOMETRICS CHART

20/28/34 Watt
DLC Premium

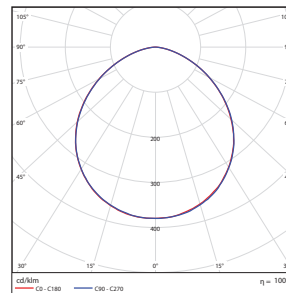

Center Beam Fc	Beam Width	
2.5ft	320 fc	6.7 ft 6.7 ft
5.0ft	79.9 fc	13.4 ft 13.4 ft
7.5ft	35.5 fc	20.1 ft 20.1 ft
10.0ft	20.0 fc	26.8 ft 26.8 ft
12.5ft	12.8 fc	33.5 ft 33.5 ft
15.0ft	8.88 fc	40.2 ft 40.2 ft

■ Vert. Spread: 106.5°
■ Horiz. Spread: 106.5°

60/80/100 Watt
DLC Premium

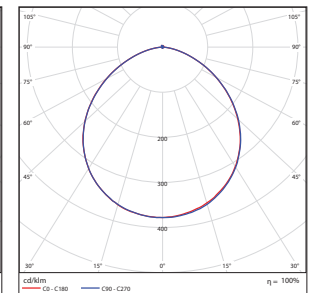

Center Beam Fc	Beam Width	
2.5ft	808 fc	6.7 ft 6.7 ft
5.0ft	202 fc	13.4 ft 13.4 ft
7.5ft	89.8 fc	20.1 ft 20.1 ft
10.0ft	50.5 fc	26.8 ft 26.8 ft
12.5ft	32.3 fc	33.5 ft 33.5 ft
15.0ft	22.4 fc	40.2 ft 40.2 ft

■ Beam Spread: 106.5°

PACKAGE

Case Qty 1 pc

